

LEAN VISUAL
MANAGEMENT



SISTEMA
KANBAN



LEAN
LOGISTIC



GREEN
FRAME

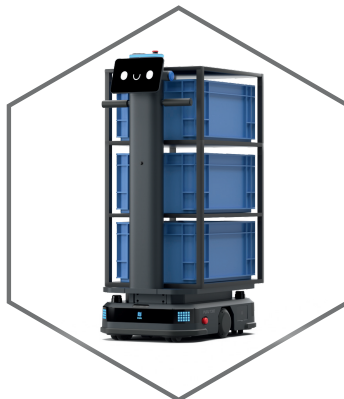

LOGISTIC
AUTOMATION



MATERIAL
HANDLING

**Prodotti e Soluzioni per
implementare i principi della
Lean Manufacturing**



Lean Visual Management

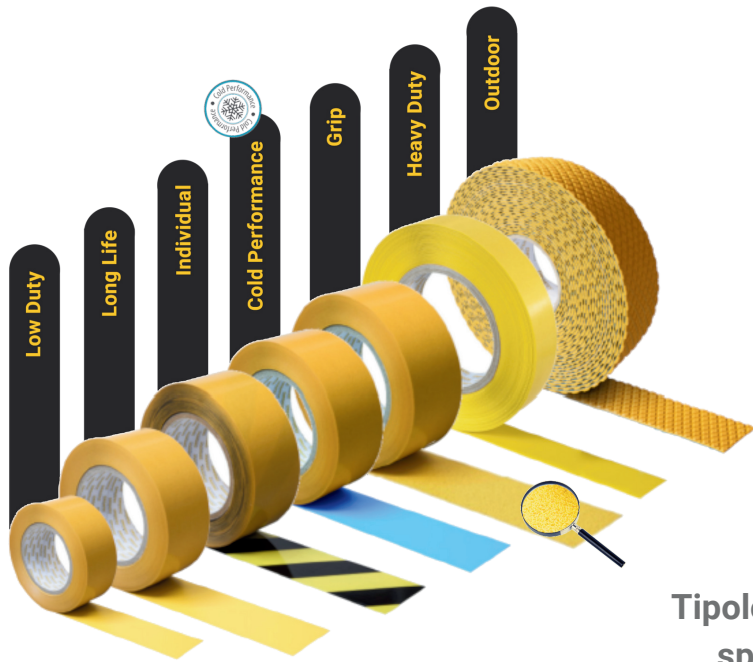

Una visione più chiara!

Identificazione ottimale nei processi produttivi

- Segnaletica orizzontale per la delimitazione di aree produttive, zone, percorsi e sicurezza
- Portadocumenti per contenitori e scaffalature
- Segnaletica per sospensione
- Magnetic windows®
- Lavagne informative modulari
- Lean Factory Corner

Tipologie, dimensioni e colori per le esigenze specifiche degli ambienti di produzione

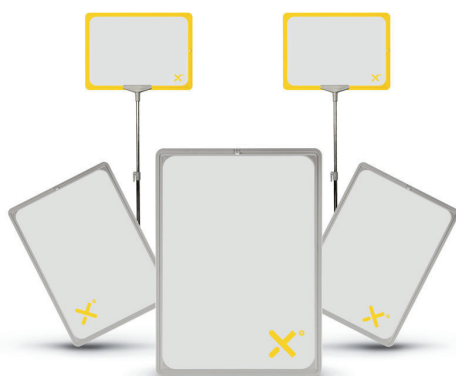
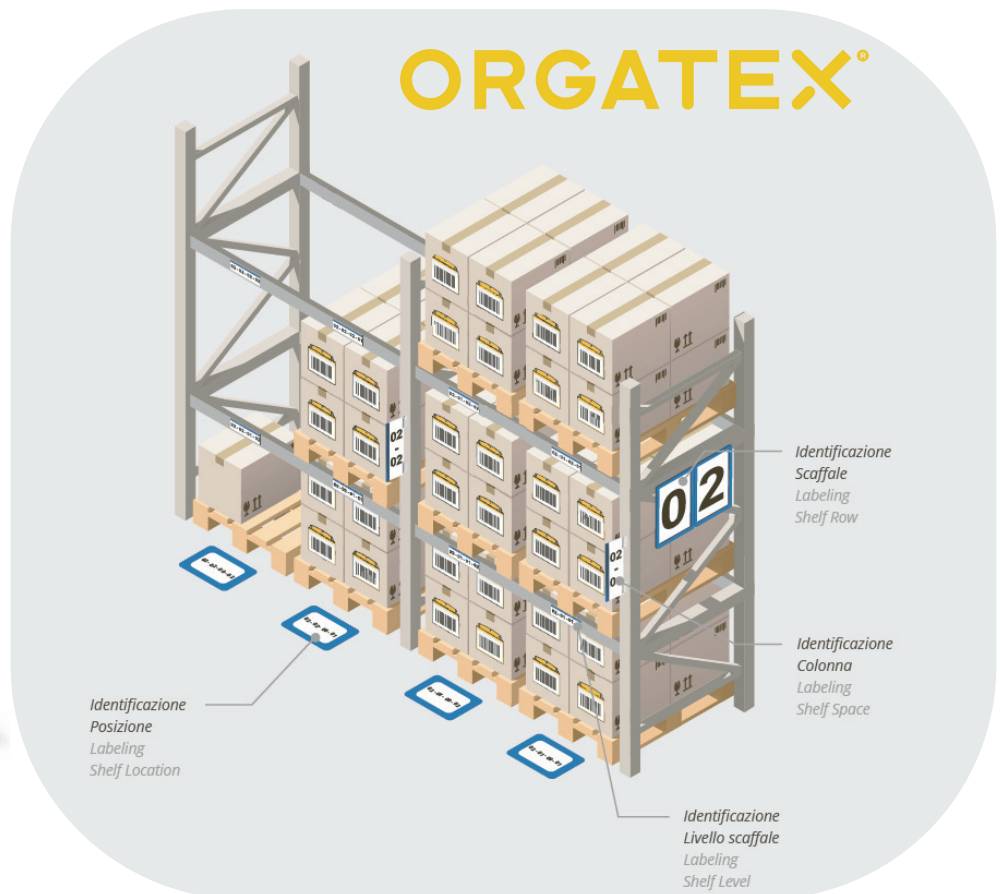

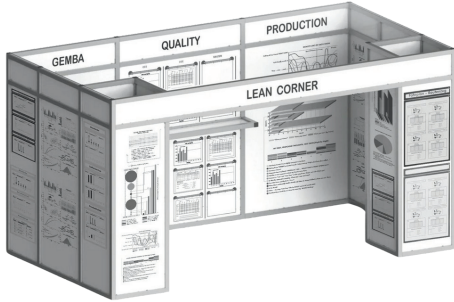

Sistema Kanban



Produzione Just-In-Time!

Principio "PULL"
si produce solamente quello
che il cliente ordina



Componenti per implementare il Sistema Kamban

- Cartellini Kanban
- Lavagne semaforo Kanban
- Lavagne Heijunka
- Lavagne Lot-Size





Ottimizzare il flusso del materiale!

Semplifica la movimentazioni dei componenti, migliorando la logistica

- Dolly e Adaptor Pallet "SLC"
- Dolly Pallet e Dolly Taxi "LLC"
- Zincatura Blu **EN-ISO 2081**
- **Milkrun** trasporto componenti
- Sistemi **FIFO Station** e **Park Station**
- Contenitori in plastica **KLT**
- Coperchi con **cinghia integrata** per evitare l'utilizzo del film estensibile

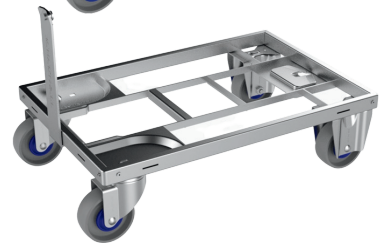
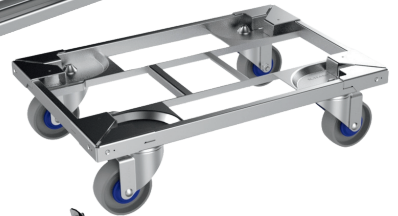
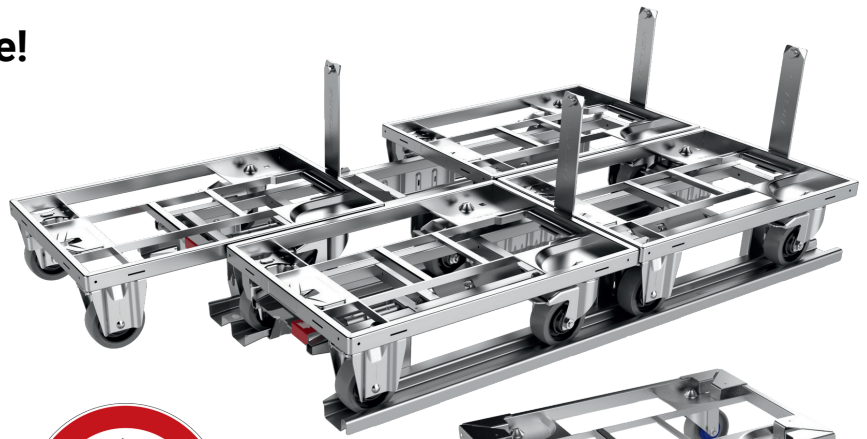

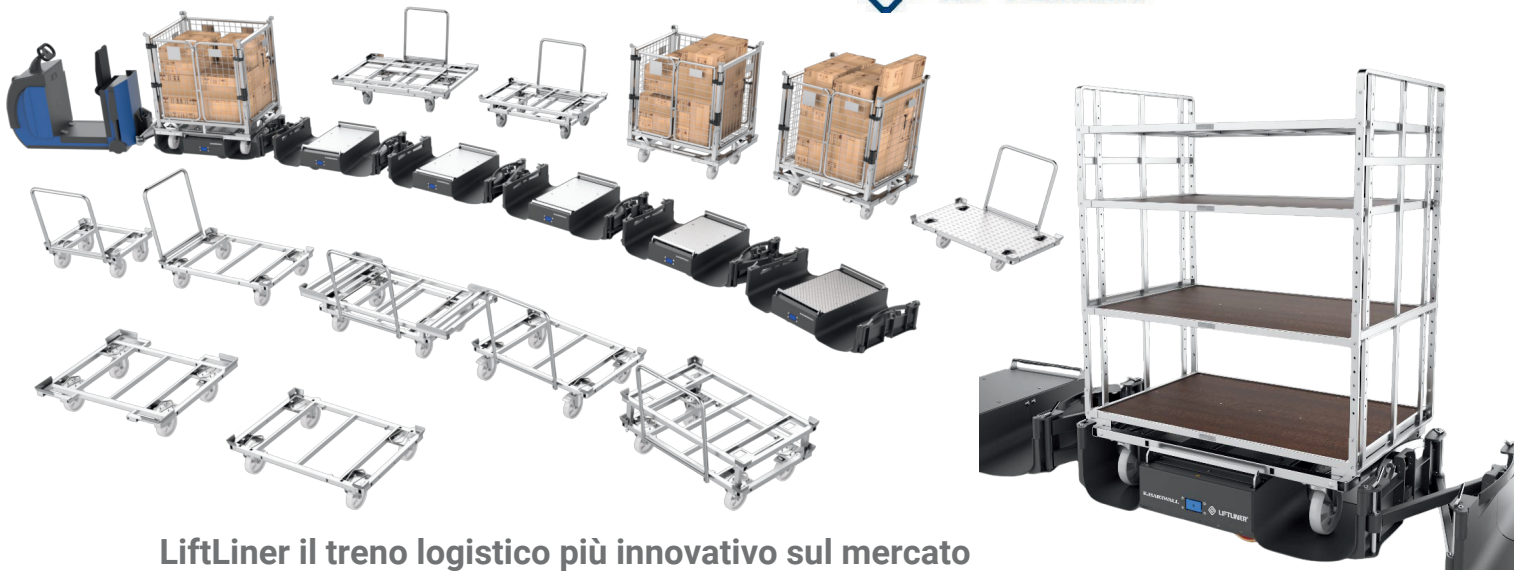

LiftLiner il treno logistico più innovativo sul mercato

- Per un'ambiente **Fork-Lift-Free**
- Da **2 a 8** unità di carico collegate con **sistema a Forbice** per un ottimo tracciamento e una lunghezza treno ridotta
- Utilizzo in contemporanea di carrelli porta pallet e a ripiani con dimensioni: 800x600, 1200x800 e 1200x1000 mm
- **Inclinazione** per agevolare l'Ergonomia durante la fase di scarico carrello
- Possibilità di carico/scarico da ambo i lati
- Sistema completamente **Elettrico**, quasi esente da **manutenzione**
- Prodotto **brevettato** da K.Hartwall



PUDU T300 - Automazione intelligente per la tua logistica

La nuova generazione di robot AMR

Pudu T300 è il robot autonomo per la logistica che ottimizza la movimentazione interna, aumentando l'efficienza e riducendo i costi operativi. Grazie alla sua intelligenza artificiale avanzata e al sistema di navigazione di precisione, T300 è la soluzione ideale per magazzini, industrie e centri di distribuzione.



- Interfaccia tablet da 10"
- Velocità 1,2 m/s
- Run-time 6-12 ore
- Ricarica 2 ore (0-90 %)



Portata 300 Kg



Navigazione in spazi ristretti 60 cm



Certificazione CE EN-ISO 3691-4



Navigazione Lidar SLAM + Visual SLAM



Ampia scelta di accessori



24/7 ricarica automatica e batteria intercambiabile

Un solo prodotto con molteplici utilizzi



Modalità Standard
Appoggia il tuo prodotto e parti



Modalità Scaffale
Ogni destinazione ha la sua posizione



Modalità Sollevamento
Carrelli o scaffali max 1200 x 1000 mm



Modalità Traino
Traino singolo carrello e multi-carrello max 400 Kg e 5 m

Modalità di consegna Automatica e Semi-Automatica

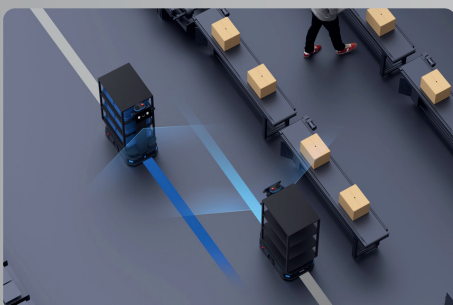

Modalità Consegna Automatica



Modalità Follow Me



Modalità Servo Assistita

PUDUBOT 2 - Picking e delivery robot

Il PuduBot 2 è un robot avanzato che assiste gli operatori nelle attività di picking e delivery. Pensato per ridurre il carico di lavoro manuale

- Interfaccia tablet da 10"
- Ricarica automatica
- Vassoi regolabili 500 x 432 mm soluzioni custom su richiesta
- Sensori e telecamere RGBD Wide FOV
- Navigazione Visual SLAM + Lidar SLAM
- Dual-LiDAR per una visione a 360°
- Velocità 0,5 - 1,2 m/s
- Carico max 40 Kg
- Durata batteria 10 - 24 ore
- Spazio di passaggio 80 cm



Ecosistema PUDU

- PUDU App Link (iOS + Android)
- Pager
- 4G Watch
- Pudu Cloud



PUDU CC1 - Pulizia flessibile quattro-in-uno

Multifunzione: Lavasciuga, aspirazione, spazzatrice e rimozione polvere. Tutte le esigenze di pulizia facilmente soddisfatte da una sola macchina

- Pulisce ogni superficie grazie ai suoi accessori e modalità di lavoro
- Docking station: Ricarica e sostituzione liquidi automatica
- Serbatoio 15 L acqua pulita e acqua di recupero
- Programmazione intelligente: Schedulazione e chiamata manuale
- Pulisce gli angoli più difficili grazie alla spazzola laterale
- Generazione report sul lavoro eseguito
- 9 ore di autonomia
- Pulisce da 700 a 1000 m²/ora in base alla modalità
- Navigazione Lidar SLAM + Visual SLAM

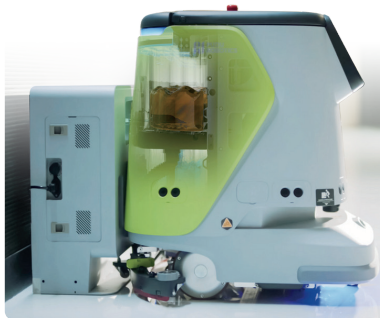

PUDU MT1 - Spazzatrice robotica con IA

Pudu MT1 è il primo robot spazzatrice autonomo al mondo con intelligenza artificiale, progettato per grandi ambienti. Offre prestazioni di pulizia eccellenti

- Programmazione intelligente: Schedulazione e chiamata manuale
- Fino a 1800 m²/ora in mod. standard
- Fino a 6000 m²/ora in mod. mirata
- Capacità 35 L
- Autonomia 4-8 ore a seconda della modalità
- Velocità 0,2 - 1,2 m/s
- Ricarica automatica
- Navigazione Lidar SLAM + Visual SLAM
- Generazione report sul lavoro eseguito
- Spazio di passaggio 75 cm



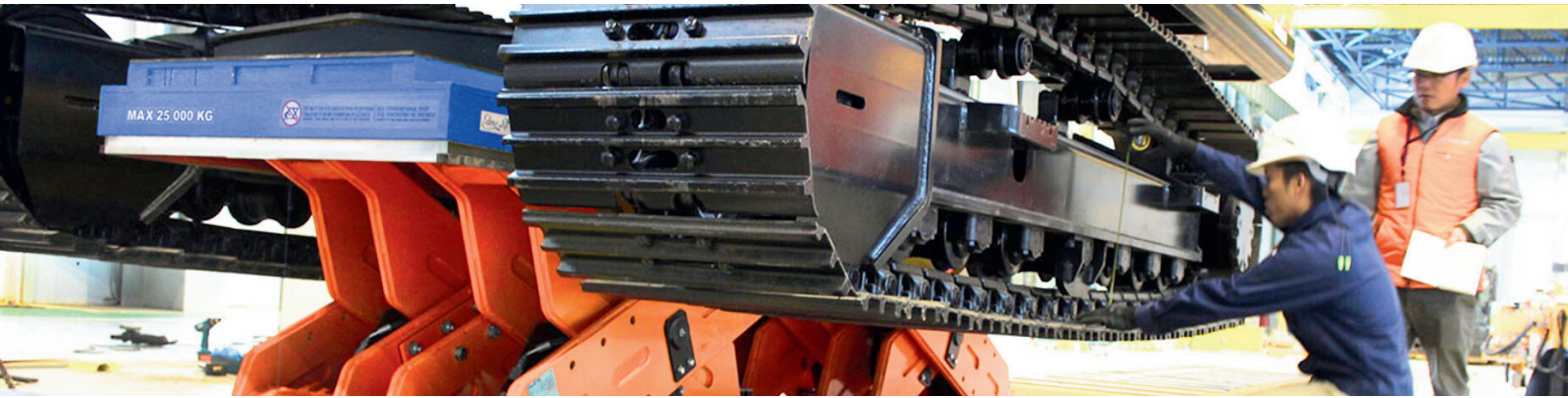

Ergonomia = Sicurezza

Piattaforme di sollevamento a pantografo, dispositivi per la movimentazione di pallet e prodotti per il Material Handling e Work Positioner

- Più di 300 modelli standard con portate che vanno dai **200 Kg** fino a **10.000 Kg**
- Soluzioni speciali custom per esigenze particolari
- Centralina elettronica **UC-60** con funzionalità Plug & Play
- Tutti i prodotti sono marchiati normativa **CE** **EN 1570-1** e corredati da dichiarazione di conformità
- Servizio di assistenza e manutenzione



• Singolo pantografo



• Doppio pantografo Verticale

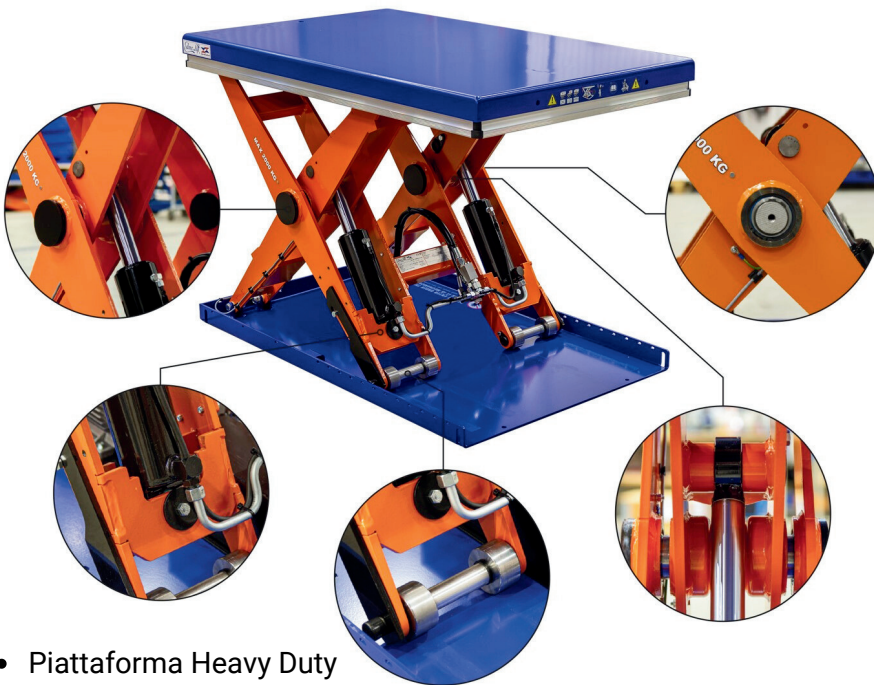

• Piattaforma Heavy Duty

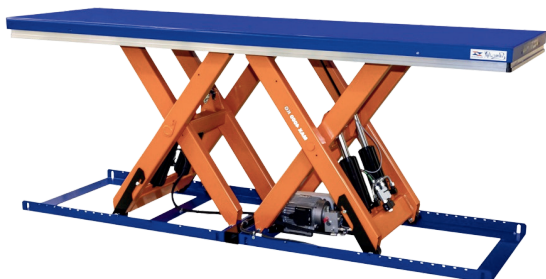

• Doppio pantografo Orizzontale



• Piattaforme Ribassate

• LTT 750

• ArmLift®

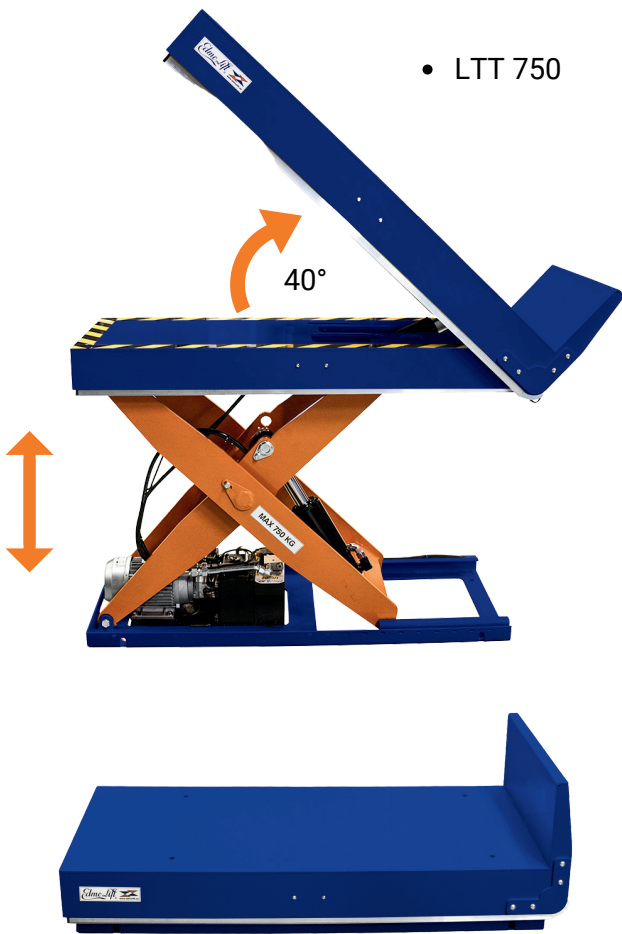

Sistemi di sollevamento e inclinazione per migliorare l'Ergonomia



• ArmLift® ARZ per Milkrun

• Carrelli a pantografo

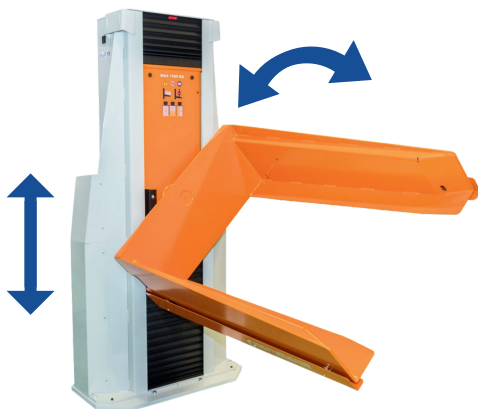

• Sollevatore per pallet con inclinazione



• WorkPositioner sollevatore elettronico



One-Piece-Flow! Profilato in alluminio con una vasta gamma di accessori per le vostre soluzioni Kaizen

1. Ambiente / Produzione

- Completamente **riciclabile**
- Profilati e componenti prodotti secondo normativa **REACH**
- Adatti a camere grigie / ESD



2. Risparmio di tempo

- 4 cave esterne per fissaggio connettori
- Accessori forniti premontati
- **Poka-Yoke** per strutture perfette
- Fissaggio con aggancio meccanico
- Perpendicolarità e parallelismo
- Assemblaggio e regolazioni facilitate dall'utilizzo di una sola vite

3. Peso ridotto

- Il peso complessivo viene ridotto del **40%** rispetto all'utilizzo del classico tubolare e giunti in acciaio

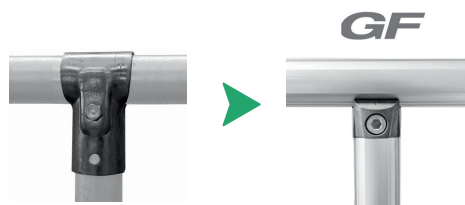

400 g
Profilo: 520 g/m
Giunto: 145 g

230g
Profilo: 367g/m
Giunto: 61g

4. Estetica

- **Manutenzione eliminata** ed eccellente impatto estetico grazie all'anodizzazione e alla progettazione degli accessori in esecuzione esterna e interna
- Eliminato il rischio di deterioramento, con conseguente polvere, ruggine e manutenzione aggiuntiva, tipico del tubolare in acciaio ricoperto



NEW DESIGN

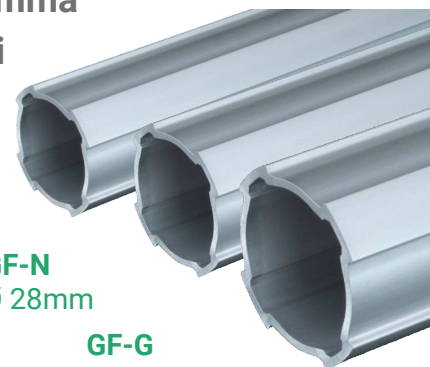

GF-S
Ø 19mm

GF-N
Ø 28mm

GF-G
Ø 43mm

Riferimenti per quote



5. Universale

- Accessori per il collegamento con profilato quadrato e tubolare ricoperto

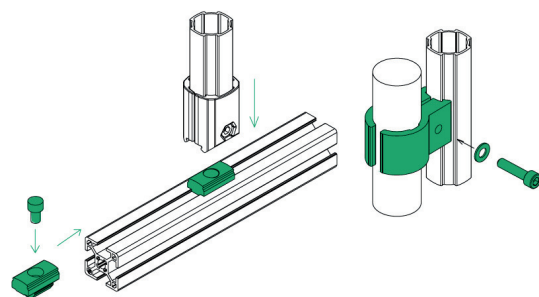

Accessori di nuova generazione con viti e bulloni in alluminio



- Profili e accessori **Green Frame** sono lo strumento base per soluzioni **Lean Manufacturing**
- Postazioni di lavoro ergonomiche singole o concatenate
- Postazioni **regolabili** in altezza
- Accessori per una corretta disposizione dei componenti
- Magazzini **Supermarket** dinamici
- Rulliere a **gravità**

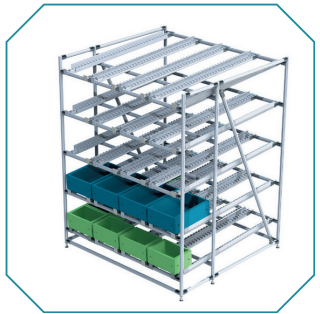
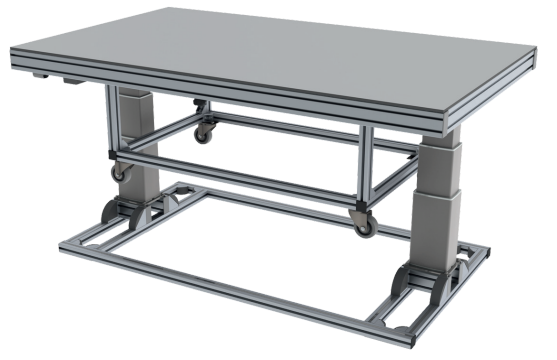
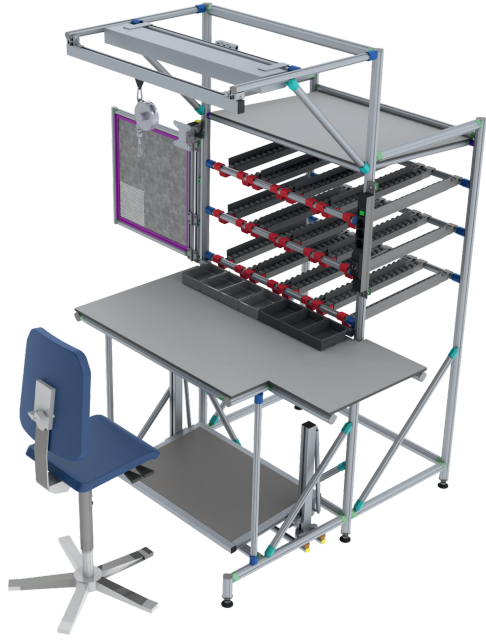
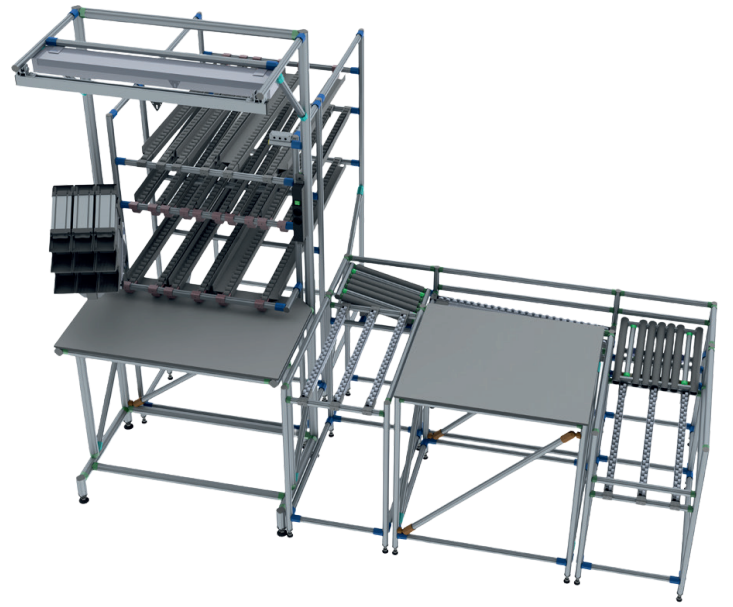

Componenti elettrici

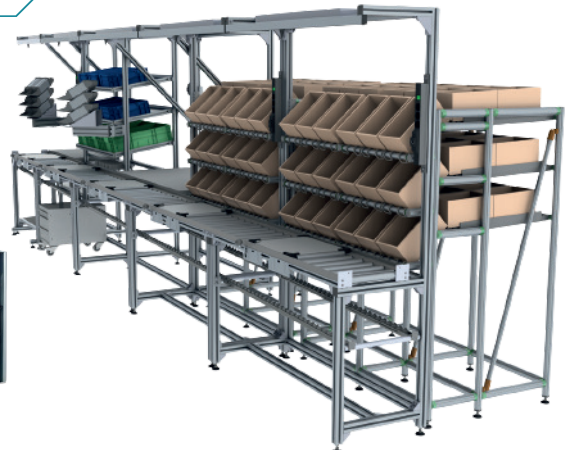
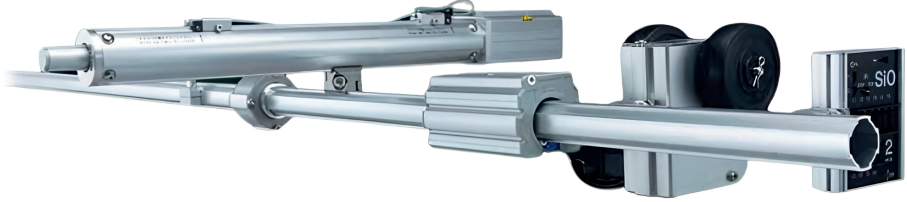



Sedie e Tappeti Ergonomici



- Sedie con ruote
- Sedie con base fissa
- Sedie in materiale lavabile
- Sedie ESD
- Sedie speciali
- Sedie per requisiti speciali
- Braccioli regolabili
- Sgabelli
- Supporti renali
- Pedane poggia piedi
- Tappeti ergonomici



LeanProducts srl

Via Pietro Bassani 6-8, 33170 Pordenone (PN) - Italy
 C.F./P.IVA 01640790935
 info@LeanProducts.eu | T +39 0434 572757

Www.LeanProducts.eu

Versione 2025 v.1